

CONVEYORS

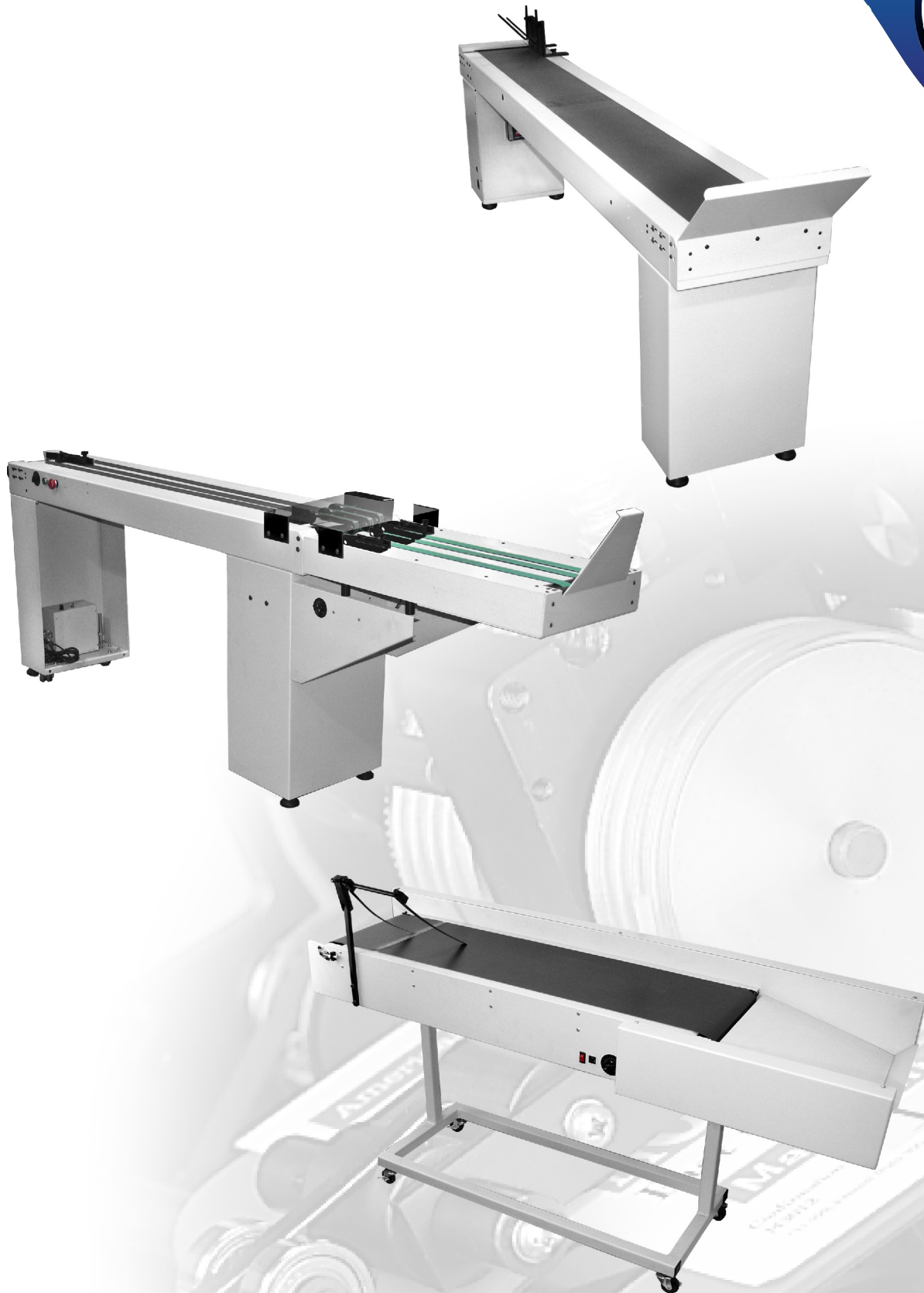

TYPE OF UNITS: Product & Feeder Stands



For more information contact your
authorized dealer at: 1-800-INSERTER(467-3783)



Small Product Vacuum Conveyor

► **Features** - The SP (Small Product) Vacuum Conveyor is ideal for transferring "small products" to the variable speed 3' Extension Shingling Conveyor. The SP Conveyor is equipped with a Transfer Collector Device to ensure a perfect shingle.

| TECHNICAL SPECIFICATIONS | |
|-------------------------------|------------------------------|
| Small Product Vacuum Conveyor | |
| Minimum Product Size | 2" W x 3" L |
| Maximum Product Width | 11" |
| Maximum Height | 40" |
| Minimum Height | 36" |
| Speed | Variable up to 700 ft / min. |
| Conveyor Length | 6' or 9' |
| Warranty | 2 Year Limited |

All Specifications are subject to change.



Slow Moving Collection

► **Features** - The Slow Moving (SM) Collection is used to accumulate shingled product from an ink jet. The SM Collection has Variable Speed with a maximum speed of 100' per minute. 90° Product Knockdown and solid body construction are standard features.

| TECHNICAL SPECIFICATIONS | |
|---------------------------|------------------------------|
| Slow Moving Collection | |
| Maximum Product Width | 15" |
| Maximum Height | 40" |
| Minimum Height | 36" |
| Speed / Slow Moving Coll. | Variable up to 100 ft / min. |
| Conveyor Length | 6' or 9' |
| Warranty | 2 Year Limited |

All Specifications are subject to change.



Vacuum Conveyor

► **Features** - The Vacuum Conveyor has an endless 2" vacuum belt and 2 adjustable product transport belts to accommodate a variety of widths and types of materials. Nip rollers & product guides assist in control of material.

| TECHNICAL SPECIFICATIONS | |
|--------------------------|------------------------------|
| Vacuum Conveyor | |
| Maximum Product Width | 15" |
| Maximum Height | 36" |
| Minimum Height | 40" |
| Speed | Variable up to 700 ft / min. |
| Conveyor Length | 6' or 9' |
| Warranty | 2 Year Limited |

All Specifications are subject to change.



Inserter Shingling Conveyor

► **Features** - The Inserter Shingling Conveyor is typically used to accumulate product from an inserter. The Inserter Shingling Conveyor has variable speed belt with a maximum speed of 100' per minute and is adjustable vertical and horizontal.

| TECHNICAL SPECIFICATIONS | |
|-----------------------------|------------------------------|
| Inserter Shingling Conveyor | |
| Maximum Product Width | 15" |
| Maximum Height | 34" |
| Minimum Height | 28" |
| Speed / Slow Moving Coll. | Variable up to 100 ft / min. |
| Warranty | 2 Year Limited |

All Specifications are subject to change.