



*Shown with optional stainless steel adjustable casters and transfer table.*

# Fully Automatic Uniform Case Taper

The **BEL 250**'s innovative design emphasizes safety, simple operation, and rugged construction all contained within the smallest footprint of any fully automatic case taper.

The **BEL 250** is equipped with stainless steel DEKKA High Performance tape heads to provide sealing speeds up to 25 cases per

minute on a wide range of case sizes.

The **BEL 250** is the premier model in the **BEL** line of case tapers and its sturdy corrosion resistant construction will provide years of dependable performance in high demand production environments.

# Fully Automatic Uniform Top and Bottom Case Taper

At 58 inches (1,473 mm) in length the **BEL 250** is the most compact automatic case sealer available. Constructed from corrosion resistant, heavy duty anodized high tensile aluminum, plated steel, stainless steel and engineering grade plastics assures that the **BEL 250** will stand up to the most demanding production environments. Because it is paint free the **BEL 250** is ideal for applications where contamination from flaking and peeling paint caused by corrosion may be a problem.

**BEL's** innovative *Uni-Drive* conveyor system synchronizes conveyor belt speed thus eliminating case skew and improving performance by ensuring that cases are taped squarely.

**BEL** automatic case sealers feature Belcor's *Snap Folder* safe flap folding technology. This revolutionary new design protects the safety of personnel by eliminating the traditional "flap kicker"

which can cause serious injury. *Snap Folders* eliminate the need for expensive, cumbersome machine guarding.

The **BEL 250** is equipped with all stainless steel DEKKA High Performance tape heads that are easily loaded in or out of the machine in 30 seconds or less. DEKKA's exclusive "No Break" tape advance delivers unbeatable reliability and production efficiency with all tape qualities.

The **BEL 250** is user-friendly and very simple to operate. A case size change can be completed from either side of the machine in under one minute using two hand wheel adjustments. The **BEL 250** represents the best value in quality production duty automatic case sealing equipment.

## Standard Features

- **BEL's** revolutionary *Snap Folder* design safely folds top flaps and eliminates the use of a dangerous flap kicker which can cause injuries.
- Slim profile high tensile aluminum "C-Beam" frame resists corrosion and enables easy access to bottom tape head.
- Paint free finish guards against contamination from flaking or peeling paint.
- Centrally positioned magnetic motor starter protects operator from accidental re-starts after a power interruption and protects motor against overload.
- *Uni-Drive* speed synchronized conveyor belts keep cases square during taping.
- Endless loop rough top belts are fully supported by "V" grooved idler rollers to keep belts running straight.
- Open top pulleys enable drive belts to be replaced in minutes reducing maintenance and down time.
- All stainless DEKKA High Performance tape heads are easily loaded in or out of the machine in 30 seconds or less.
- DEKKA's exclusive "No Break" tape advance delivers reliable performance with all brands and qualities of pressure sensitive tapes.



Snap Folder

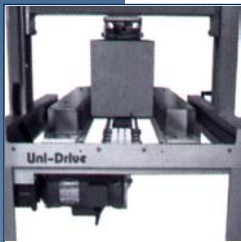

Uni-Drive



DEKKA Tape Head

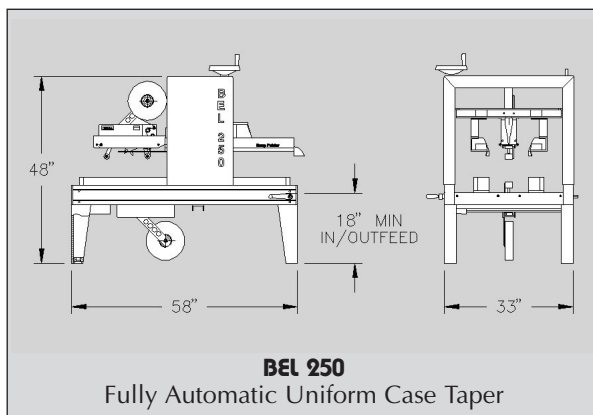

## Machine Specifications

### Electrical

- NEMA 12 standard, 110 VAC, 60 cycle, 1 phase (other voltages available)

### Air

- 0.1 CF/cycle @ 80 P.S.I. 6 Bars

### Drive System

- Speed synchronized *Uni-Drive* side belts powered by 1/2 H.P. TEFC motor and 3/4 H.P. rated gear reducer.
- Rough top continuous loop stepped splice and "V" backed belts.
- Conveyor speed 85 feet per minute.

### Construction

- Heavy duty corrosion resistant high tensile aluminum.
- Paint free anodized aluminum plated and stainless finishes, and all stainless fasteners.
- Wide frame arch, 4 lead screw vertical adjustment.
- Linked *Snap Folder* and drive belt case size adjustment.

### Speed

- Up to 25 cases per minute depending upon box size.

### Shipping Weight

- 750 lbs.
- Machine weight = 635 lbs.

| Case Size Range              |  | BEL 250          |
|------------------------------|--|------------------|
| Length                       | min.                                     | 8" / 203 mm      |
|                              | max.                                     | 20" / 508 mm     |
| Width                        | min.                                     | 6" / 152 mm      |
|                              | max.                                     | 15" / 381 mm     |
| Height                       | min.                                     | 4 1/2" / 114 mm  |
|                              | max.                                     | 15 3/4" / 400 mm |
| <b>Infeed/Outfeed Height</b> |  |                  |
| Minimum                      | 19 1/2" / 495 mm with adj leg extensions |                  |
| Maximum                      | 28 3/4" / 730 mm                         |                  |
| <b>Tape Heads</b>            |  |                  |
| Standard                     | DEKKA 22                                 | 2" / 51 mm       |
| Optional                     | DEKKA 23                                 | 3" / 76 mm       |

For other case requirements consult factory or local distributor. Specifications are subject to change without notice.

|                       |
|-----------------------|
| <b>Distributed by</b> |
|-----------------------|

Manufactured by

**BELCOR**  
INDUSTRIES INC.

"PREMIER BUILDERS OF QUALITY PACKAGING MACHINERY"

### Corporate Office

#1 - 14211 Burrows Road  
Richmond, B.C., Canada V6V 1K9  
Tel (604) 270-0811  
Fax (604) 270-7897  
email: sales@belcor.com

### Sales Offices

Dallas, TX  
Chicago, IL  
Portland, OR