

LEG EXTENSION OPTIONS

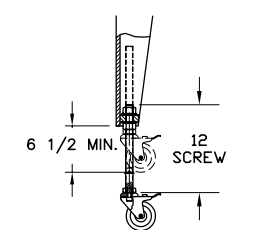
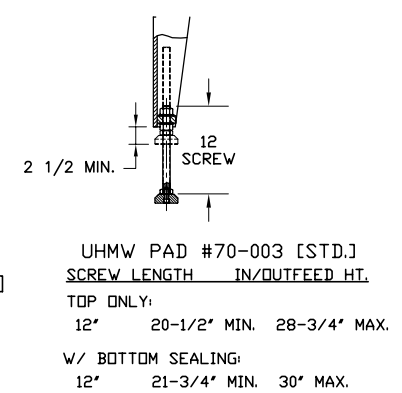

REV	DESCRIPTION	DATE	APPROVED
07	UPDATED	03-11-26	BY PV
06	CORRECTED EXTENSION OPT. HEIGHTS	03-05-29	BY PV
05	UPDATE	03-05-14	BY PV
04	SINGLE [MODEL] SPACE VERSION	99-03-11	PRV

MATERIAL:	ALL DIMENSIONS IN INCHES. DO NOT SCALE DRAWING (2D DRAWING)	TOLERANCE .X ±.015 .XX ±.010 .XXX ±.005 FRACT.: ±1/32	BELCOR INDUSTRIES INC. TITLE: BEL 270 HOT MELT GLUE TOP & BOTTOM CASE SEALER
SIZE: CODE: 55-200	MODEL: 270	DRAWN BY: PRV	
FINISH:	COLOR:	DATE (Y-M-D): 95-11-20	DWG No: 75-130
REVISIONS			APPROVED BY: REV: 07